

# QUAD GUN TRACTOR

1/35 MILITARY MINIATURE SERIES

BRITISH COMMONWEALTH FORCES QUAD GUN TRACTOR CANADIAN FO

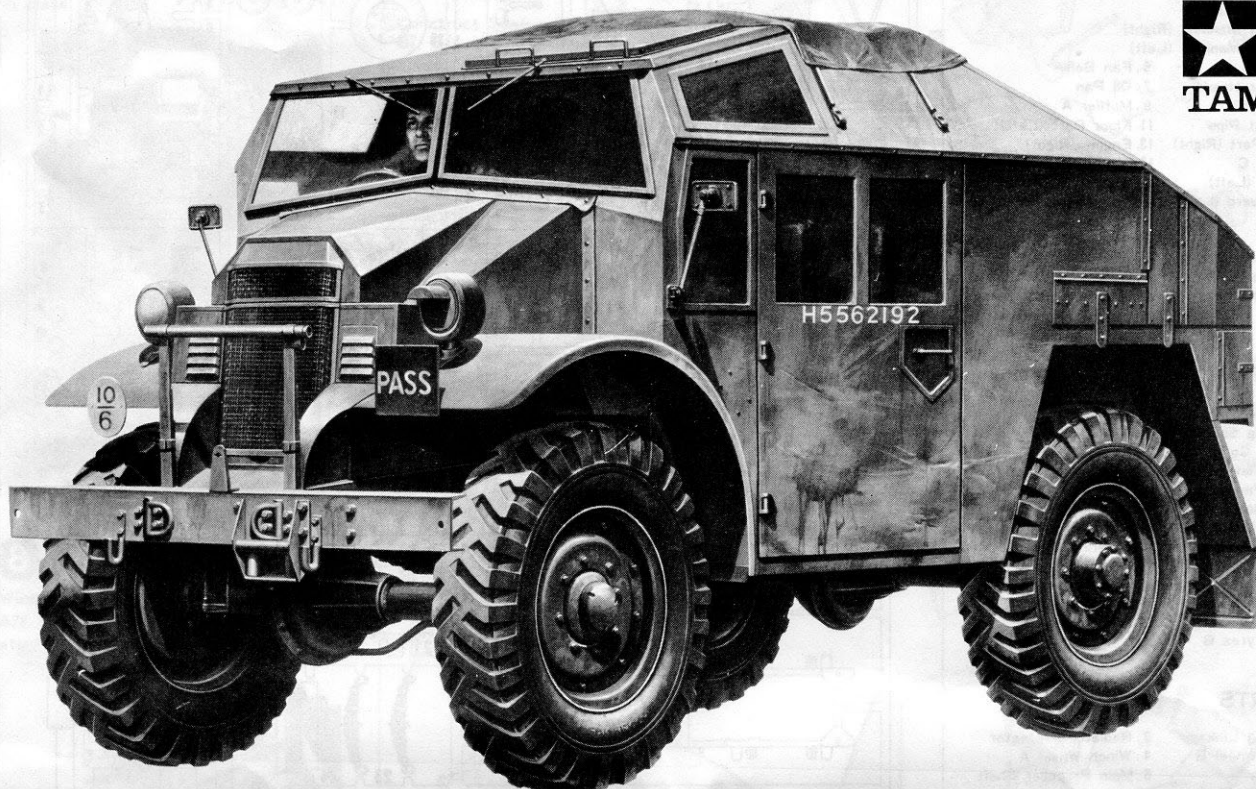

After the beginning of World War I, motorcars which had just been put to practical use attracted the attention of the military by their mobility and came to be used for various military purposes. At about the middle stage of the war, motorcars naturally began to be used for hauling guns in place of horses which had been used for that purpose so far. Soon after this, many nations started the study and development to give greater mobility to guns through the employment of motorcars. Military vehicles thus developed were divided broadly into various categories: armoured cars, tanks and self-propelled guns that carried guns themselves; and gun tractors that were designed for hauling guns: The first gun tractors devised were full-track vehicles with caterpillars and half-track vehicles which combined caterpillars and wheels. This was simply because motorcars of those days had less powerful engine, narrower and weaker wheels and much lower performance than those of today, did not have the satisfactory cross-country ability needed for military purposes. Britain was far ahead of other nations in the field of full-track and half-track gun tractors. In the period of 1920—1930, the British developed in cooperation with the French a large number of full-tracks and half-tracks. In the meantime, the performance and reliability of motorcars was being improved rapidly. Recognizing that motorcars had come to have more satisfactory performance, the British ceased using full-tracks and half-tracks which had complicated mechanism and were very costly, and officially developed several tractors designed solely for hauling guns. On the other hand, the Germans continued studying half-tracks, which developed into a variety of tractors and personnel carriers that were widely used during World War II.

It was a series of unique-shaped gun tractors called "Quad" which carried a squarish body on

## ◀ Quad Variants ▶

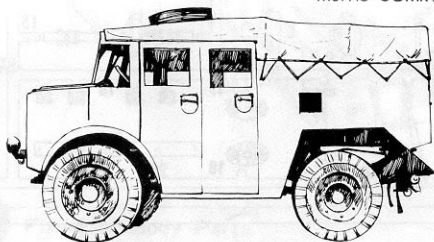

Morris C8Mk II

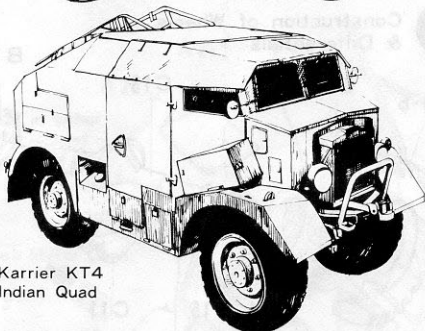

Karrier KT4  
Indian Quad

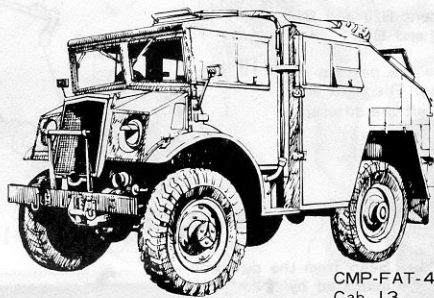

CMP-FAT-4  
Cab 13

a short-wheelbase chassis with broad, large tires that the British frequently used for hauling guns during World War II. These gun tractors divided broadly into the following: Guy Carleton Karrier KT 4 Indian Quad, and Canadian Pattern (CMP) Quad manufactured in Canada. Of these four Quads, the CMP Quad was used in the greatest quantity and was the most commonly used in the war.

At the request of the British War Office, Morris Motors developed and delivered in April 1930 a tractor of very unique shape designed to haul a 18 and 25 pounder guns. The tractor, which was called "Ant" and looked like a small armoured car, had good ground clearance to facilitate its cross-country ability, short wheelbase to improve its turning circle and driver seat in the most forward possible position to facilitate its cross-country ability. The back of the body was cut off so that the gun platform of a 25-pounder gun could be hoisted and fixed onto it by means of a crane reel when the vehicle was to carry the gun from one place to another and at the same time the vehicle could accommodate six men. These features necessarily resulted in the unique shape of the tractor. The all-metal enclosed body had a small uncovered portion at the top which was an ideal design, but the British War Office did not accept it for production. Thereafter, the War Office placed an order with Morris Motors for an FGT (field gun tractor) on the chassis of their C8 track. The C8 FGT divided into the Mk I with a totally enclosed body and the Mk II of the semi-open body. The most unique-shaped vehicle of all military vehicles was nicknamed "Quad" and was loved by the soldiers using these vehicles. The Karrier KT 4 Indian Quad manufactured by the Karrier for the Indians was the largest

# PARTS

## A PARTS

1. Breather Cap
2. Exhaust Manifold (Right)
3. Exhaust Manifold (Left)
4. Fan
5. Fan Belt
6. Cylinder Heads
7. Oil Pan
8. Muffler B
9. Muffler A
10. Exhaust Pipe
11. Floor Part (Left)
12. Floor Part (Right)
13. Engine (Right)
14. Muffler C
15. Air Cleaner
16. Engine (Left)
17. Starter Motor
18. Mud Guard (Left)
19. Mud Guard (Right)
20. Hood
21. Canvas Stay
22. Hatch
23. Air Duct Lids
24. Side Door (Left)
25. Side Door (Right)
26. Radiator Grille
27. Bonnet
28. Rear Bulkhead
29. Engine House (Left)
30. Engine House (Right)

## B PARTS

1. Transfer Case Shift Lever
2. Steering Shaft
3. Change Lever
4. Engine Cover
5. Rear View Mirror (Left)
6. Rear View Mirror (Right)
7. Seat Backs
8. Headlights B
9. Headlights A (Left)
10. Headlights A (Right)
11. Hand Brake Levers
12. Steering Wheel
13. Seat Supports
14. Seats
15. Rear Tyres C
16. Front Tyres A
17. Rear Tyres A
18. Rear Tyres
19. Front Tyres B
20. Rear Tyres
21. Rear Tyres B

## C PARTS

1. Steering Linkage
2. Radiator Protector
3. Winch Wheel B
4. Winch Wheel A
5. Chassis
6. Main Propeller Shaft
7. Propeller Shaft for Winch
8. Winch Part A
9. Winch Part B
10. Front Differential B
11. Rear Differential B
12. Front Differential A
13. Rear Differential A
14. Rear Propeller Shaft
15. Front Propeller Shaft
16. Towing Hook Support
17. Transfer Case B
18. Transfer Case A
19. Spring Parts
20. Front Bumper
21. Fuel Tank A
22. Winch Rear Roller B
23. Front Springs
24. Winch Rear Roller A
25. Rear Springs
26. Bumper Hooks
27. Towing Hook
28. Fuel Tanks B
29. Winch Brake

## A PARTS

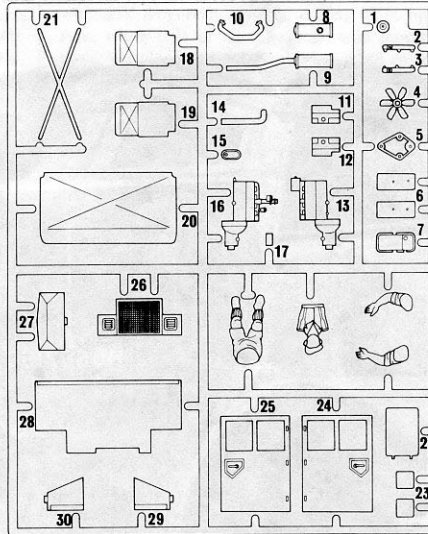

## B PARTS

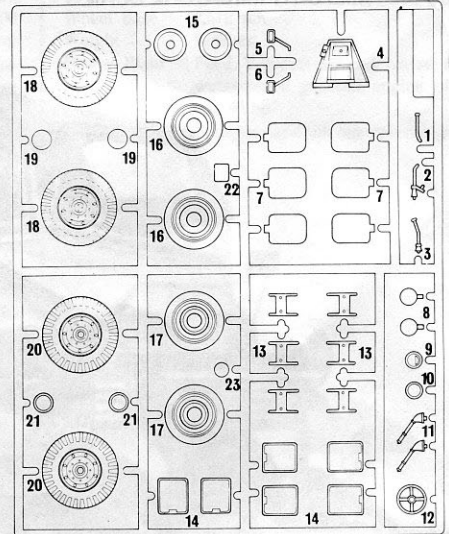

## C PARTS

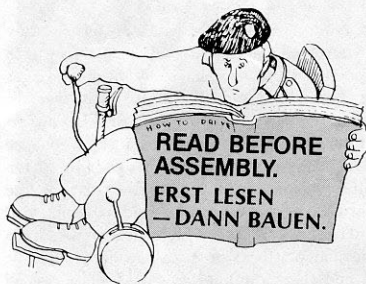
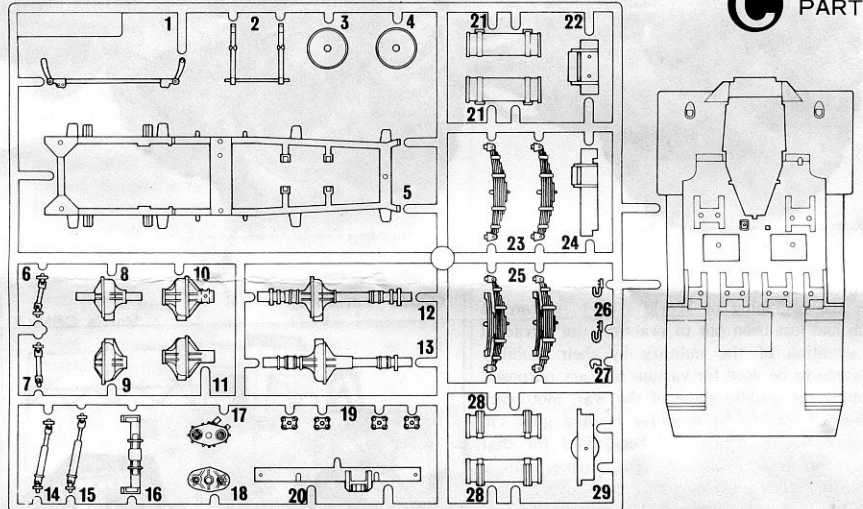

- ★ Study the instructions and photographs before commencing assembly.
- ★ You will need a sharp knife, a pair of tweezers, a pair of pliers, and a file.
- ★ Do not break parts away from sprue, but cut off carefully with a pair of pliers.
- ★ Use glue sparingly. Use only enough to make a good bond. Apply cement to both parts to be joined.

### 1 Construction of Wheels, & Differentials

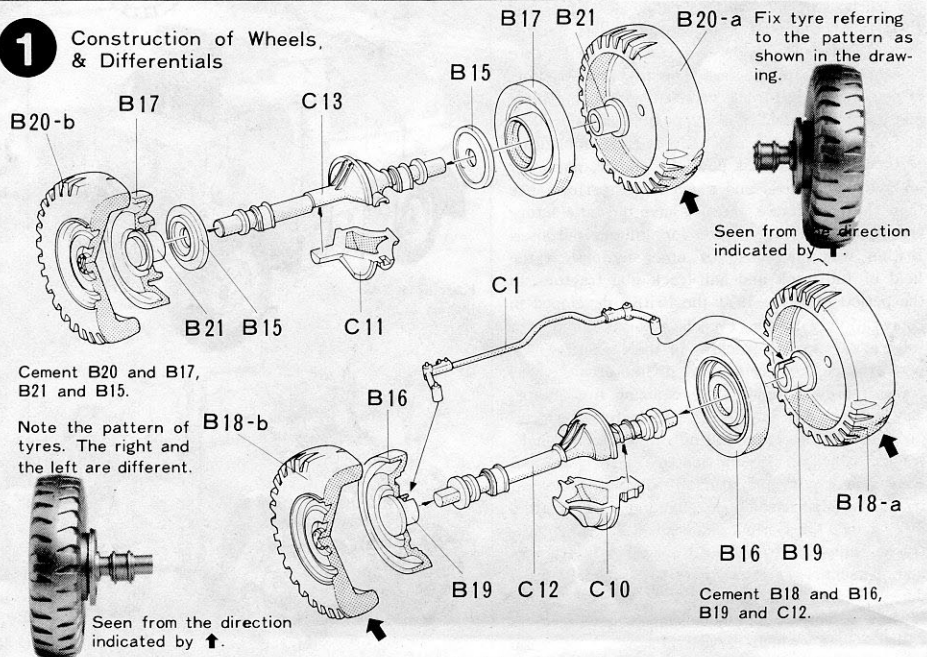

### 1 Construction of Wheels & Differentials

Tyres B18 and B20 should be fixed in respective positions as shown in the photo.

**2** (Construction of Engine)

Construct Engine Block by gluing A13 and A16 together. Then, fix necessary parts. Exhaust Pipe A10 is to be glued to Muffler A9 which will be fixed in 4, and so A10 may be glued after Engine is fixed in 5.

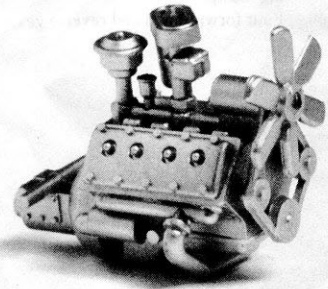

**3** (Fixing of Winch)

Winch Wheels C3 and C4 should be free to revolve. Do not put too much adhesive on them. Cement part C29 to Chassis before fixing C9 and C8.

**4** (Fixing of Transfer Case)

Cement Transfer Case and Front and Rear Springs. Construct Muffler with Parts A8, A9 and A14. Muffler may be glued after Engine is fixed in 5.

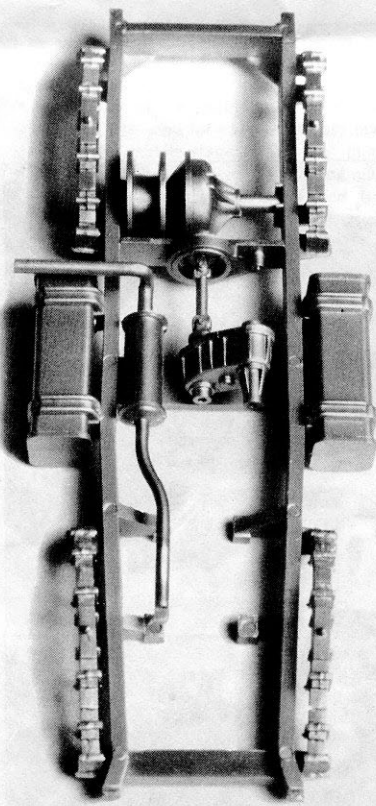

**2** Construction of Engine

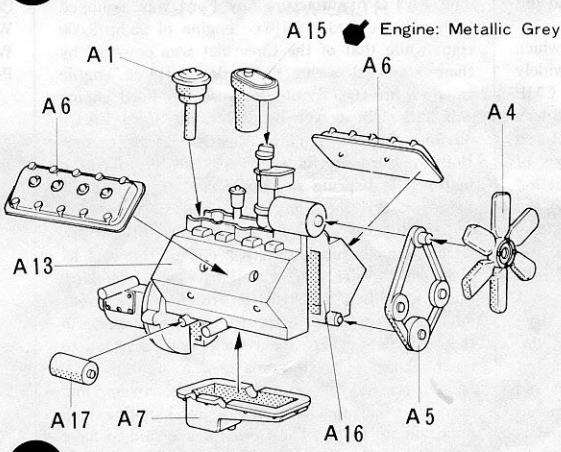

Exhaust Pipe: Rusty Iron A10

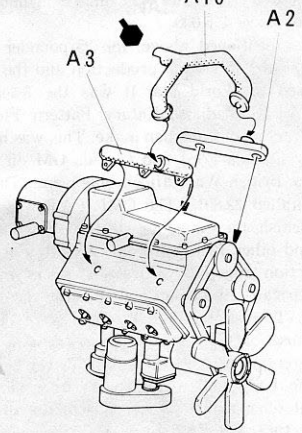

**3** Fixing of Winch

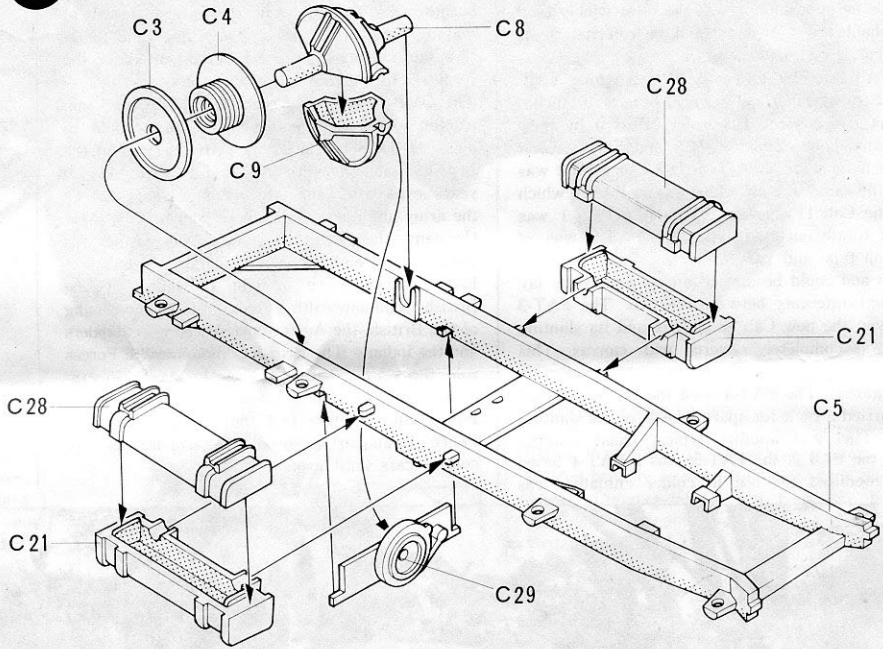

**4** Fixing of Transfer Case

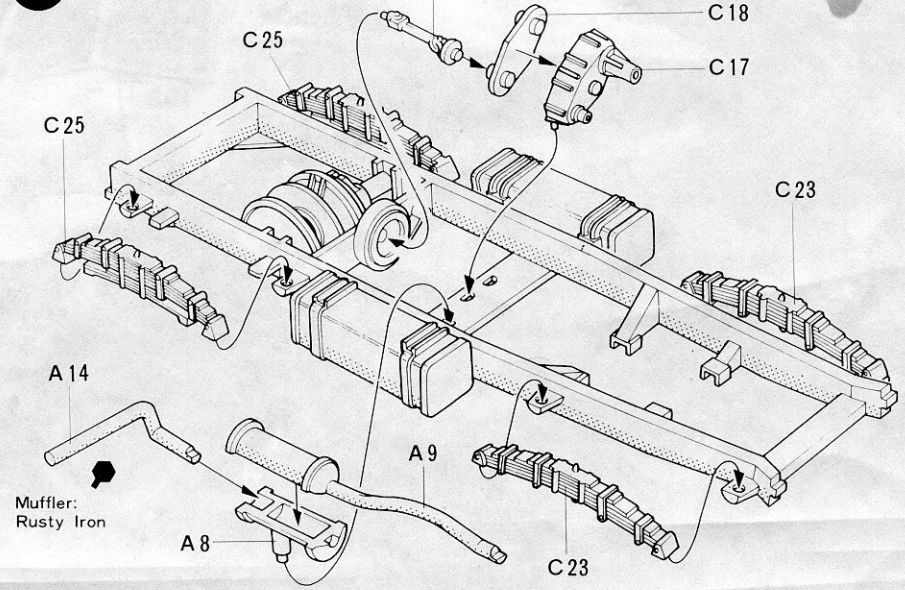

## 5 (Fixing of Differentials)

Cement Front and Rear Differentials constructed in 1 to Springs. At the same time, fix Propeller Shaft. This must be set at a correct angle.

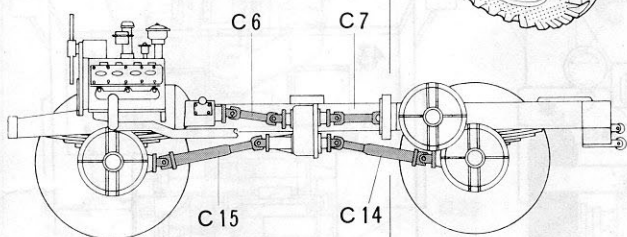

Note the angle of each Propeller Shaft.

### (Fixing of Engine)

Fix Engine to Chassis and glue Exhaust Pipe and Muffler in place. Cement Spring Part C19 using a pair of tweezers or the like.

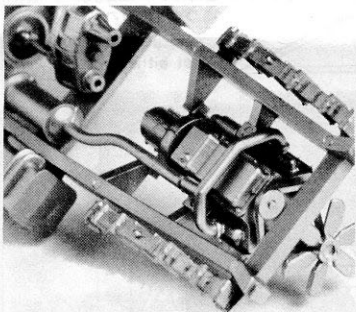

## 6 (Fixing of Front Bumper)

Cement radiator protector C2 to Front Bumper. Then, fix Front Bumper to Chassis.

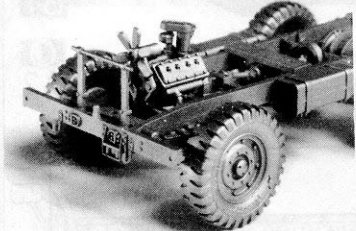

### (Fixing of Winch Roller)

Construct Winch Roller with parts C16, C22, C24 and C27. Then, fix Winch Roller to Chassis.

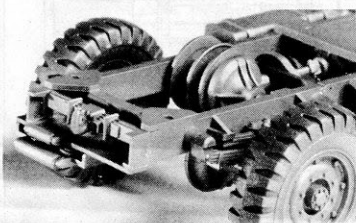

## 5 Fixing of Differentials

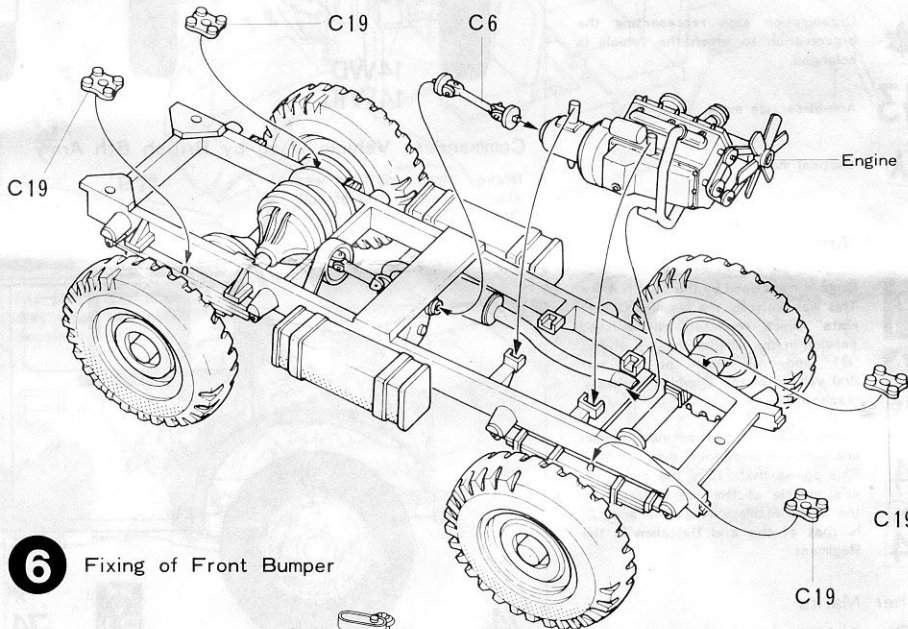
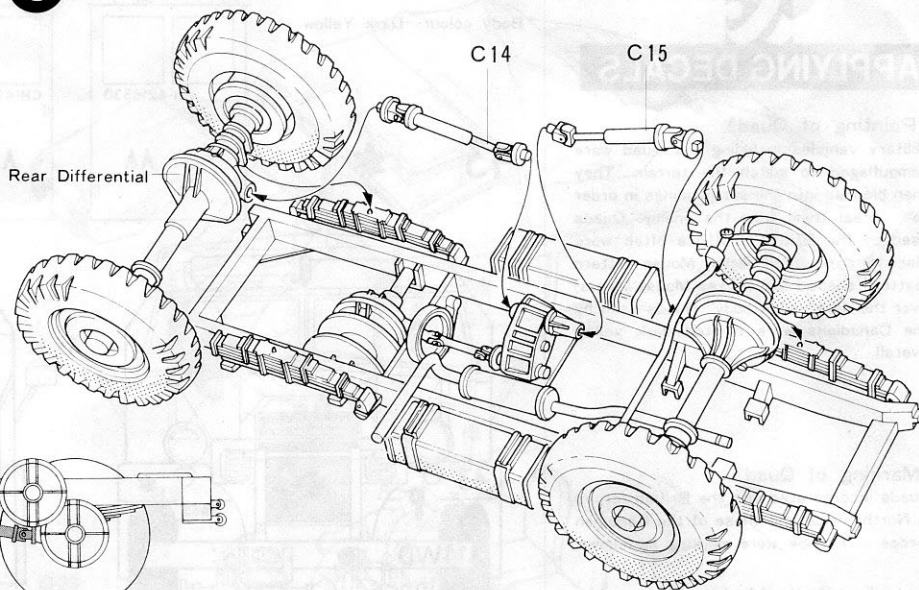

## 6 Fixing of Front Bumper

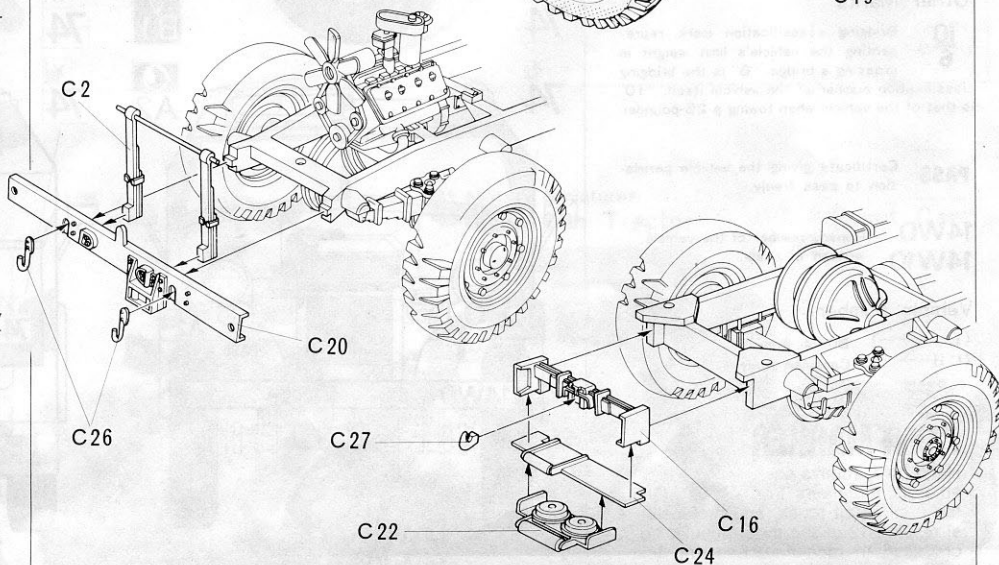

**7** (Fixing of Seats)

Six Seats of the same shape should be constructed in all. Rear Seats must be fixed after parts A11 and A12 are glued in place.

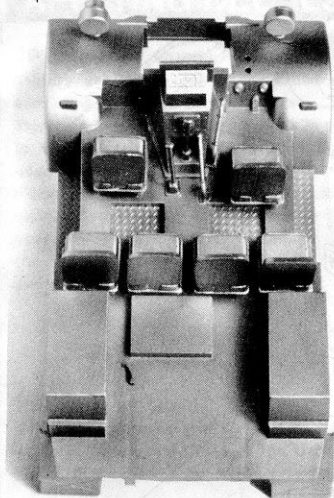

**7** Fixing of Seats

Construct Seat with B7, B14, and B13.

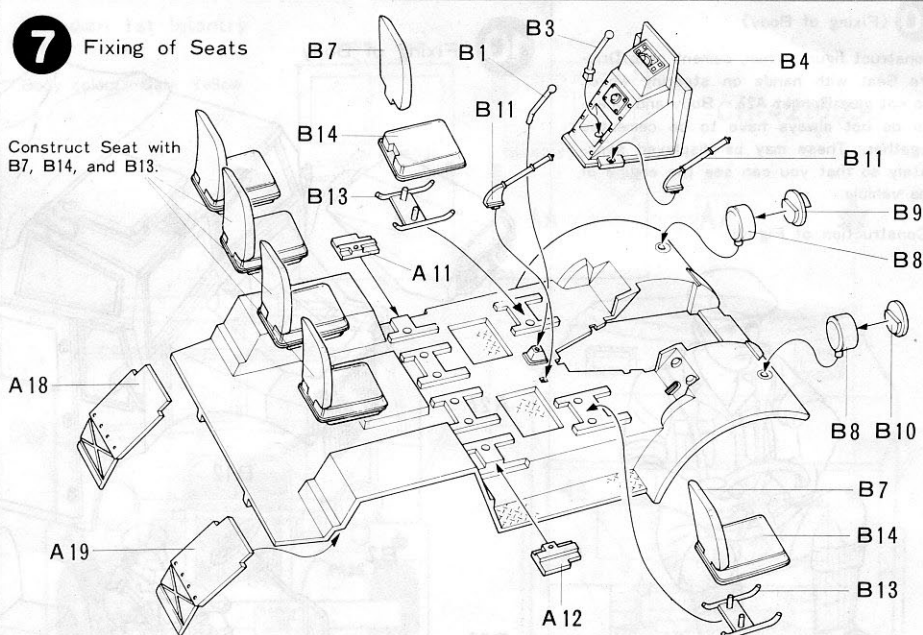

**8** (Fixing of Windscreen)

Windscreen should be fixed in place after A28 is glued to Body and must be glued after Body is painted.

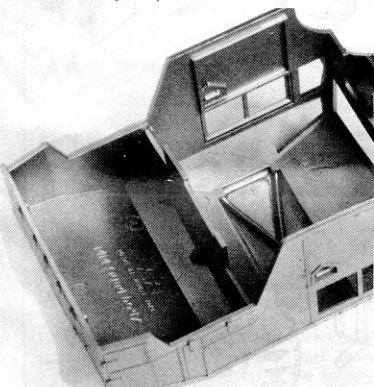

**8** Fixing of Windscreen

Fix Windscreen after you finish painting of Windscreen surroundings.

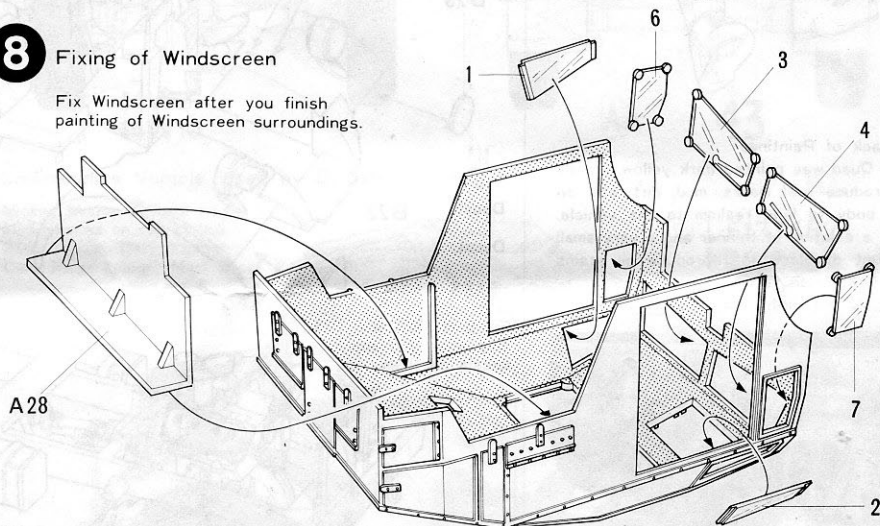

**9** (Fixing of Body Parts)

Doors A24 and A25 and Hatch A22 should be glued in either open or closed position. Hoods A20 and A21 and part A23 need not be glued. These may be left in an open position.

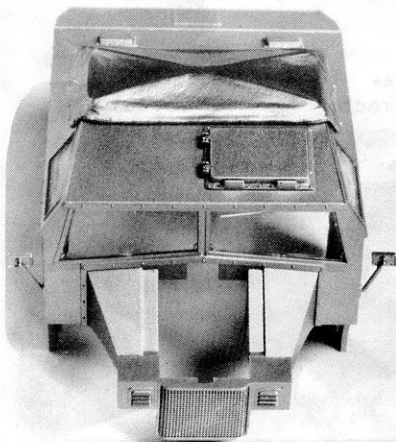

**9** Fixing of Body Parts

Fix A22 in either open or closed position.

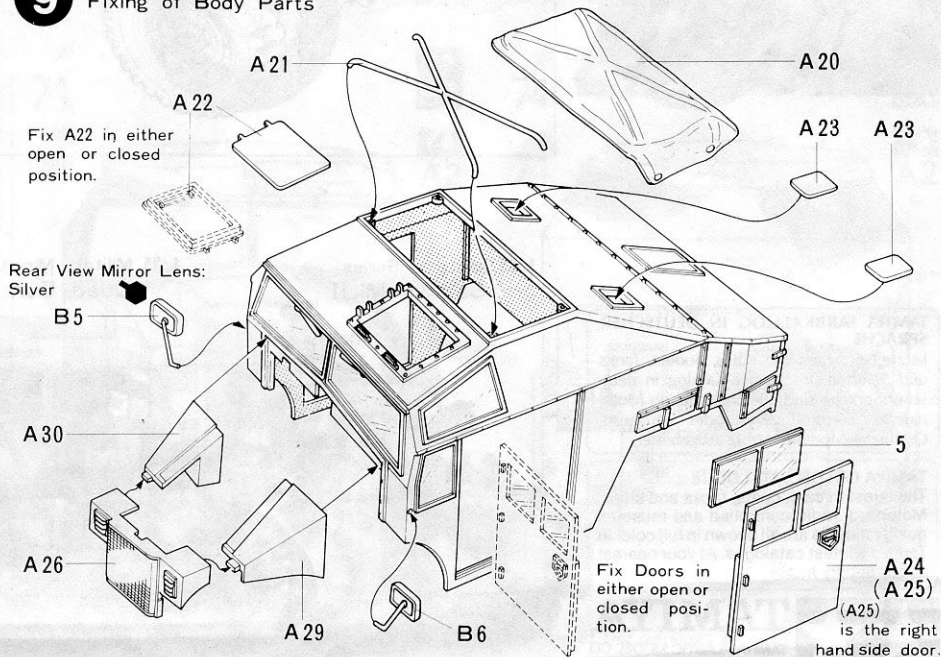

Fix Doors in either open or closed position.  
A24 (A25) is the right hand side door.

**10** <Fixing of Body>

Construct figure. Then, cement onto Drivers Seat with hands on steering wheel. Do not glue Bonnet A27. Body and Chassis do not always have to be cemented together. These may be displayed separately so that you can see the engine of the vehicle.

<Construction of Figure>



<Knack of Painting>

The Quad was painted dark yellow overall. Reproduce rust marks, mud, dirt, etc. on the body to lend realism to the vehicle. Use a solution of thinner and a very small amount of black to reproduce oil stains on differentials, etc.

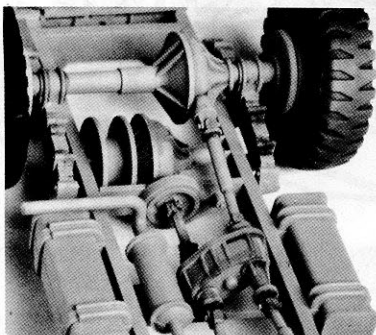

**10** Fixing of Body

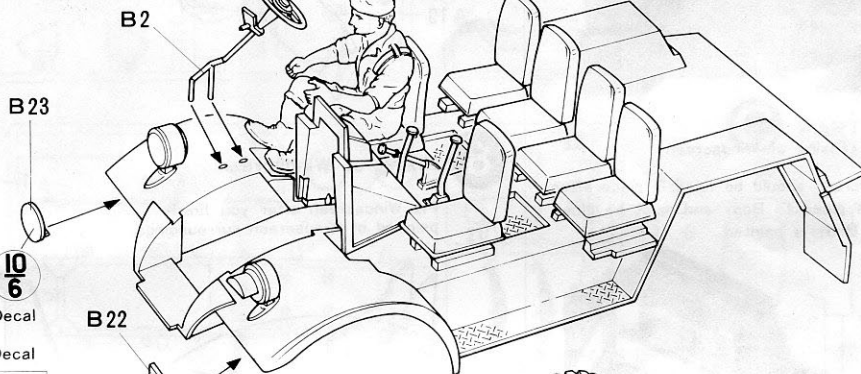
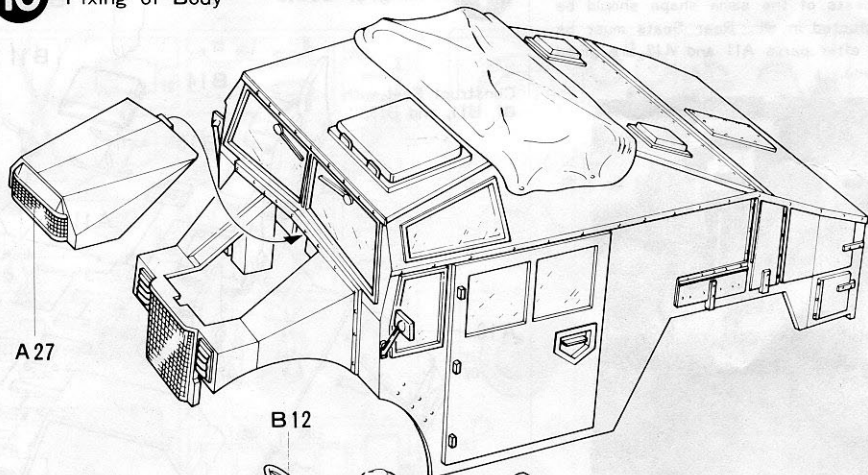

**10/6**

Decal

Decal

**PASS**

Fix parts B22 and B23 only when you apply decals on them.

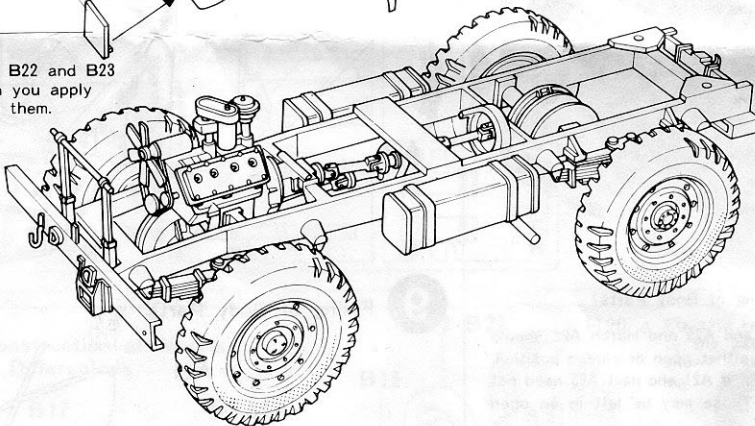

1/35 Identical Series  
Saladin Mk II

1/35 Military Miniatures  
Quad Gun Tractor

Scout Car

**TAMIYA FARBKATALOG IN DEUTSCHER SPRACHE**

Letzte Neuheiten von Autos, Booten, Tanks und Schiffen. Im Tamiya-Katalog in deutscher Sprache sind alle Modelle, ob Motorisierte, Ferngesteuerte oder Museum-Qualitates-Modelle, farbig Abgebildet.

**TAMIYA COLOR CATALOGUE**

The latest in cars, boats, tanks and ships. Motorized, radio controlled and museum quality models are all shown in full color in Tamiya's latest catalogue. At your nearest hobby supply house.



**TAMIYA**  
TAMIYA PLASTIC MODEL CO.  
3-7, ONDAMARA, SHIZUOKA-CITY, JAPAN.

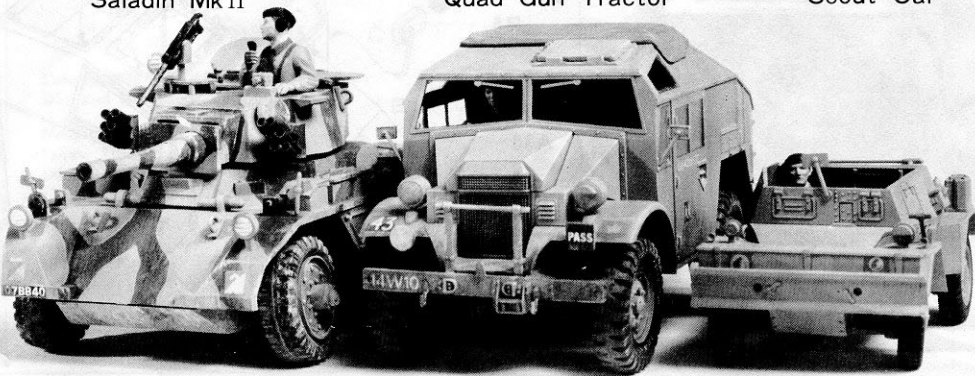

**PAINTING**



**APPLYING DECALS**

**<Painting of Quad>**

Military vehicles including the Quad were camouflaged to match the terrain. They then blended into the surroundings in order to conceal them from the enemy. Quads used by the British in Africa often wore black or dark green Mickey Mouse pattern (pattern shaped like Mickey Mouse's ears) over the dark yellow body. Quads used by the Canadians were painted dark yellow overall.





**<Marking of Quad>**

Quads incorporated into the British forces in North Africa and those of the Canadian forces in Europe wore marking as follows:

**Canadian Army Marking**

-  Organization sign representing the organization to which the vehicle is belonged.
- 43** Arm-of-service mark.
- AA** Tactical mark

**British Army Marking**

-  Brigade mark used by the Eighth Army. This was worn by the famous "Desert Rats" which rendered distinguished service in the African theatre of war. "B1" and "A2" mean the 1st and 2nd vehicle of the B and A Company respectively.
- 
- (1)  Combination of a tactical mark (upper) and an arm-of-service mark (lower). This shows that (1) is the commander's vehicle of the 1st Battalion in the Field Artillery Regiment and (2) is that of the 2nd Battalion in the Regiment.
- (2) 

**Other Marks**

-  Bridging classification mark representing the vehicle's limit weight in crossing a bridge. "6" is the bridging classification number of the vehicle itself. "10" is that of the vehicle when towing a 25-pounder.

**PASS** Certificate giving the vehicle permission to pass freely.

**14WD** Convoy number of the vehicle  
**14W10** written in chalk.

**Vehicle number**

- (L) British Army
- (CH) Canadian Army

**Canadian 1st Infantry Division**

Body colour...Dark Yellow

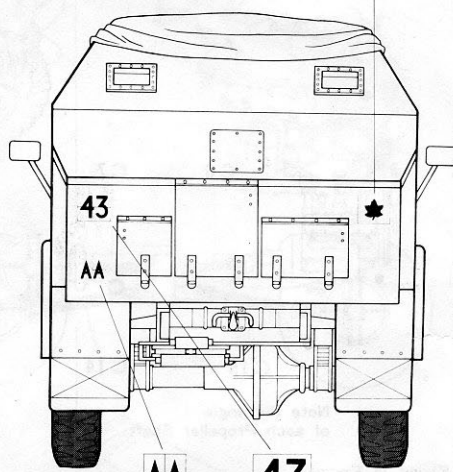
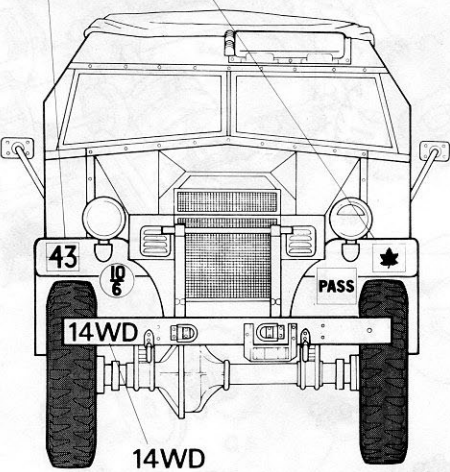
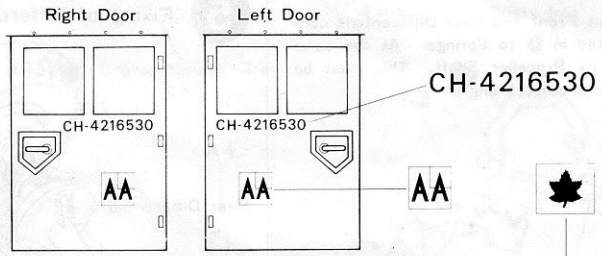

**Commanders Vehicle Used by British 8th Army**

Mickey Mouse pattern was also painted on top of hull.  
Body colour...Dark Yellow  
Camouflage colour...Matt Black or Dark Green

L 5137482  
L 2918302

Select either one of two.

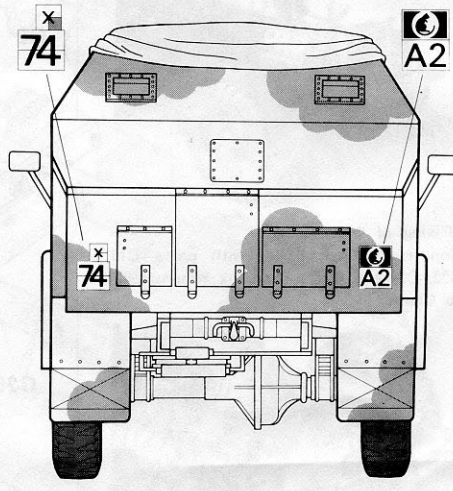
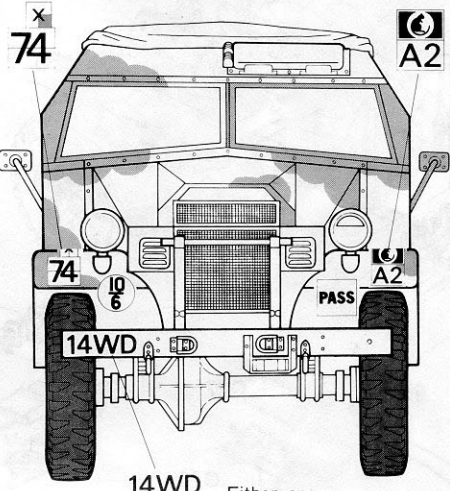
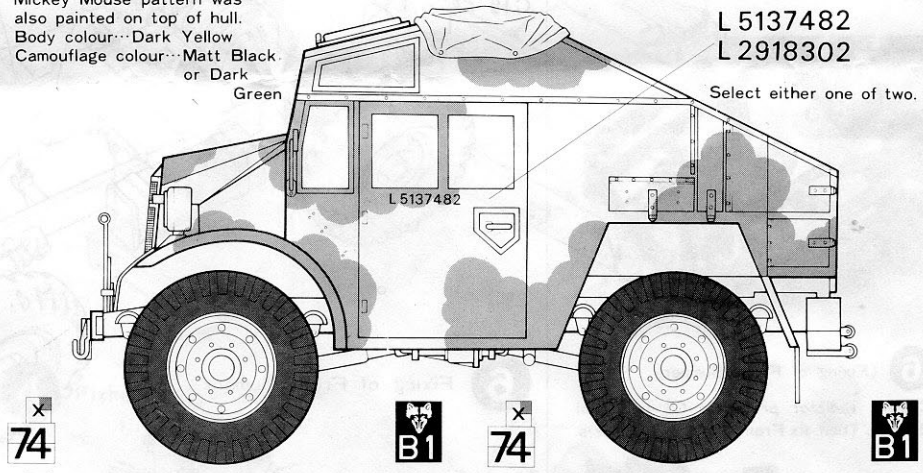

**14WD** Either one  
**14W10**

Select either one of two markings and apply.

**PAINT MARKER**  
Hand held, Tamiya enamel paint markers. For the final detail touch, and professional results. 12 of the most popular colors used in modeling. See and test them at your local hobby supply house.



designed only for hauling a 25-pounder. It may safely be said that this was a rather special version of the Quad. The production of each of these three Quads was limited in number and did not exceed 5,000.

As mentioned above, the 25-pounder FGT which was the largest in production and the most widely used in World War II was the 3-ton 4x4 CMP FAT (Canadian Military Pattern Field Artillery Tractor) of Canadian make. This was manufactured by Canada Ford and Canada GM on the basis of the British War Office's blue print. The production totalled 22,891. The CMP FAT was used by the British, the Canadians, the Australians, the Indians and other British Commonwealth Forces and saw action together with 25-pounders in the North African, European and Pacific theatres of war. FATs manufactured by Ford were different from those of GM in the chassis (engine, frame, differential and transmission), driver seats, etc., but the body and related parts were the same and interchangeable. According to the time of manufacture, the FAT may be divided into six models from the FAT-1 to the FAT-6. Of these six models, the FAT-2 (body number 7A2) whose front end reminds us of a bulldog was the most widely used throughout the war and could be referred to as a typical Quad gun tractor.

The FAT-2 used the chassis of the regular CMP Cab 12 truck which had a wheel base of 101 inches (approx. 2.57 metres). Chevrolet called it by their production code number "8440" and Ford gave it a code number of "C291 Type Q". The FAT-2 was much the same in body shape as the FAT-1 which used the Cab 11 chassis. While the FAT-1 was of the totally-enclosed type, the FAT-2 was of open-top type and part of its roof was made of canvas and could be opened and closed. Here lay the main difference between the two. The FAT-3 employed the new Cab 13 chassis and its slanting back was completely covered with canvas. This was an experimental model and the production was limited. The FAT-4 used the Cab 13 chassis and carried a rack for spare wheels on its slanting back. This was another typical Quad ranking beside the FAT-2, the FAT-5, was a FAT-4 based Quad modified for use in colder climates, was

designed by Canadian Army specialists developed towards the end of World War II. The FAT-6 was of the canvas open-top type without the slanting back. The FAT-2 manufactured by Ford was equipped with a V 8-cylinder 3,916 cc engine of 95 hp/3,600 rpm, while that of the Chevrolet was powered by their standard series 6-cylinder 3,548 cc engine rated 85 hp/3,600 rpm. Because the Ford engine was larger in power by 10 hp, the Ford FAT-2 obviously had a slightly superior performance. Both the Ford and the Chevrolet had the following features: leaf-spring suspension and rigid axle for the front and the rear, sturdy chassis of simple construction, power winch was fitted to this chassis, which could be used at either end of the vehicle. Needless to say, four wheel drive was standard. Such simplified construction offered the great advantages of being easy to use and service in the battlefield where the vehicle was subjected to much abuse. The Germans used a great number of half-tracks with complicated mechanism, and naturally had much difficulty in handling and maintaining them. The Germans are said to have vied with each other in capturing and using British vehicles in North Africa. This was probably because the British were more accustomed to making vehicles for use in the tropics and therefore their vehicles were far better suited for the tropical climate and much easier to use.

The CMP Quads including the FAT-2 Quad gun tractor were very good vehicles and simple to operate. They continued on active service in the British Commonwealth forces for about 15-20 years even after the war. Some were sold to the army and also the Japanese police, Italy, West Germany, the Netherlands and other nations for use as patrol and riot control cars. A number of FAT-2 Quads were brought to Japan by the British Commonwealth Forces in Japan consisting of the British, the Australians, the New Zealanders and the Indians. The British Commonwealth Forces sold the FAT-2 Quads to the Japanese Government when they left Japan. The Metropolitan Police Headquarters and the Osaka Prefectural Police Headquarters used the vehicles as riot control cars until around 1953.

#### ESSENTIAL SPECIFICATION OF FORD FAT-2

Overall length : 4,331 mm  
Overall width : 2,235 mm  
Overall height : 2,286 mm  
Wheel base : 2,572 mm  
Weight : 3,996 kg  
Power Plant : Ford V 8-cylinder side-valve type watercooled gasoline engine offering 95 hp.  
Transmission : Four forward and one reverse gears.

